



# **SL30, SL32, SL50, SL52, SL23 & SL24 Installation and Service Manual**

Version 3.1



## Table of Contents

<b>Introduction</b>	<b>2</b>
<b>Operating Principle</b>	<b>3</b>
<b>Technology</b>	<b>3</b>
<b>SL30 &amp; SL32 Models</b>	<b>4</b>
<b>SL50 &amp; SL52 Models</b>	<b>5</b>
<b>SL23 &amp; SL24 Models</b>	<b>6</b>
<b>Installation of all Models</b>	<b>7</b>
<b>Maintenance &amp; Servicing</b>	<b>8</b>
<b>Flash Codes</b>	<b>9</b>
<b>Troubleshooting</b>	<b>15</b>
<b>Sealite Lantern Warranty</b>	<b>16</b>

## Introduction

Congratulations! By choosing to purchase a Sealite lantern you have become the owner of one of the most advanced LED marine lanterns in the world.

Sealite Pty Ltd has been manufacturing lanterns for over 20 years, and particular care has been taken to ensure your lantern gives years of service.

As a commitment to producing the highest quality products for our customers, Sealite has been independently certified as complying with the requirements of **ISO 9001:2000** quality management system.

Sealite lanterns comply with requirements of the US Coast Guard in 33 CFR part 66 for Private Aids To Navigation.

By taking a few moments to browse through this booklet, you will become familiar with the versatility of your lantern, and be able to maximise its operating function.

Please remember to complete the Sealite warranty registration card accompanying your lantern.



## **Operating Principle**

The solar module of the lantern converts sunlight to an electrical current that is used to charge the battery. The battery provides power to operate the lantern at night.

The flasher unit has very low current requirements. A microprocessor drives an array of ultra bright LED's through a DC/DC converter, which enables the LED's to operate within the manufacturer's specifications. The battery is protected from over-charging within the circuit to ensure maximum battery life.

On darkness, the microprocessor will initiate a program check and after approximately 1 minute begin flashing to the set code.

## **Technology**

### Electronics

Sealite employs leading in-house electronic engineers in the design and development of software and related circuitry. All individual electronic components are sourced directly by Sealite procurement staff ensuring that only the highest quality components are used in our products.

### LED Technology

All marine lanterns use the latest advancements in LED (Light Emitting Diode) technology as a light source. The major advantage of LED's over traditional light sources is well established in that they typically have an operational life in excess of 100,000 hours, resulting in substantial savings to maintenance and servicing costs.

### Precision Construction

Commitment to investing in the design and construction of injection-moulded parts including optic lenses, light bases and a range of other components ensures that all Sealite products are of a consistent and superior quality.

### Optical Performance

Sealite manufactures a range of marine LED lenses moulded from multi-cavity dies. Complex shapes such as the SL70 lens are a testament to the company's superior in-house lens manufacturing capabilities and outstanding optical performance.

### Award-winning, Patented Technology

Several United States and Australian patent registrations are held on Sealite's range of innovative designs, with other regional patents pending in Canada, United Kingdom and Europe.



## **SL30 & SL32 Models**

Sealite's SL30 (1x 2watt solar module) and SL32 (2x 2watt solar modules) 3-4nm LED self-contained lanterns incorporate some of the most advanced technology available, and are designed to be maintenance-free and have a service life of over 5 years. Performing well in medium-high sunlight regions, the units are ideal for fixed and buoy installations including navigation, hazard lighting, perimeter lighting and a range of other applications.

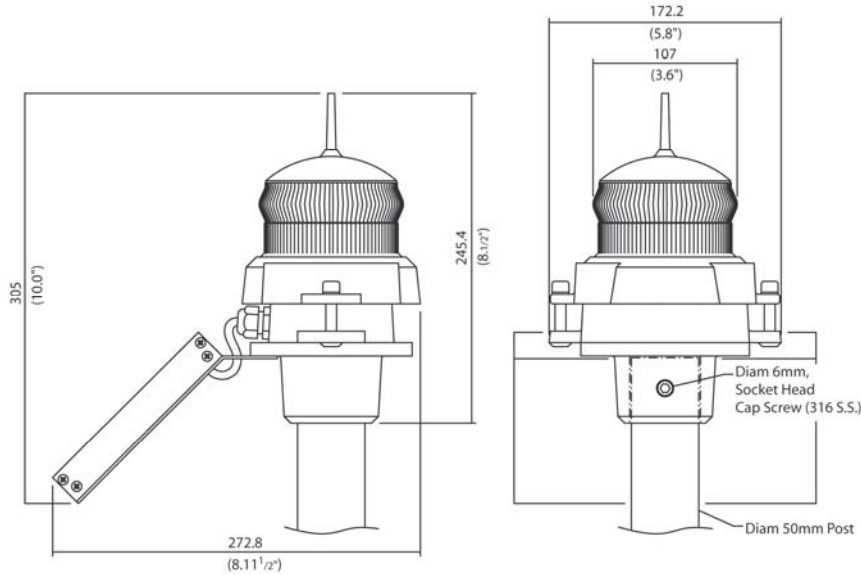

SL30 Model (fixed installation)

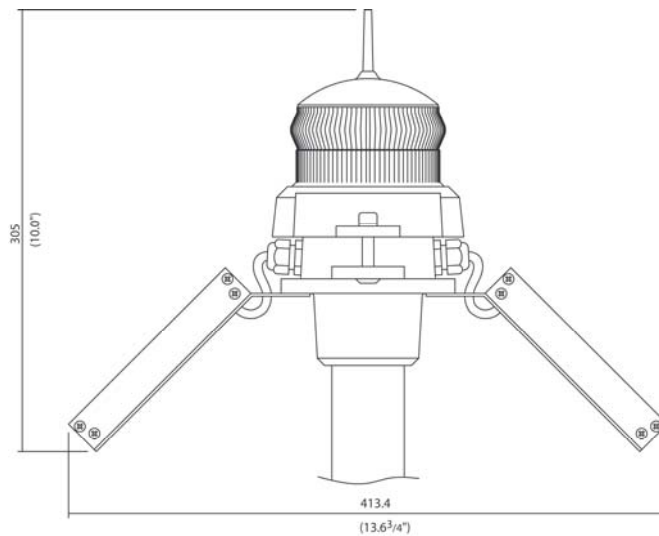

SL32 Model (buoy installation)



## SL50 & SL52 Models

Sealite's SL50 (1x 5watt solar module) and SL52 (2x 5watt solar modules) 3-4nm LED self-contained lanterns have been widely adopted by many professionals in the marine sector, including ports and harbours, transport departments, and coast guards.

The larger 5watt solar module(s) and 4.5Ah battery of these lanterns ensures reliable and efficient operation at higher duty cycles, or in lower sunlight regions.

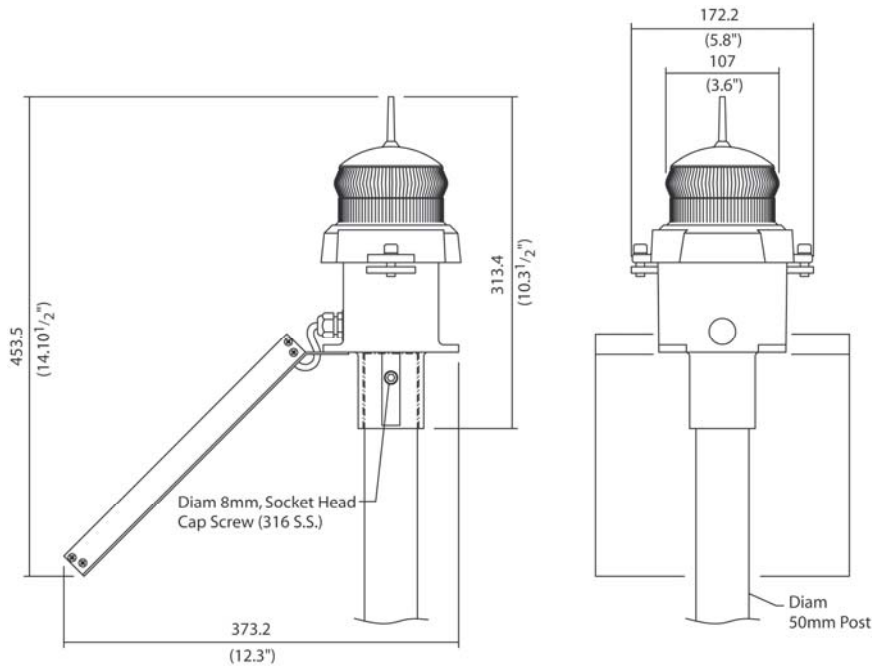

SL50 Model (fixed installation)

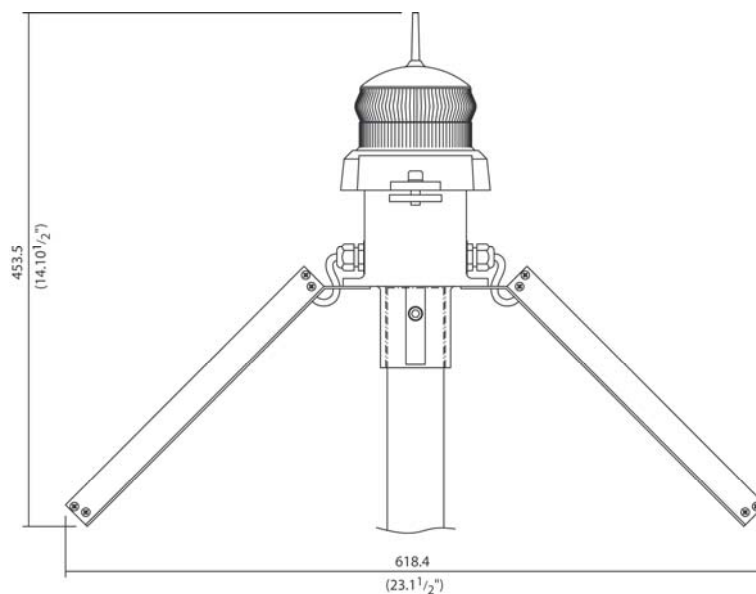

SL52 Model (buoy installation)



## SL23 & SL24 Models

The SL23 (1x 12watt solar module) and SL24 (2x 12watt solar modules) 3-4nm lanterns are the workhorse of Sealite's LED self contained lantern range. Specifically designed to operate reliably in a range of low sunlight regions, or as steady-on lights, the units' 7.5Ah battery provides a larger 25 day autonomy.

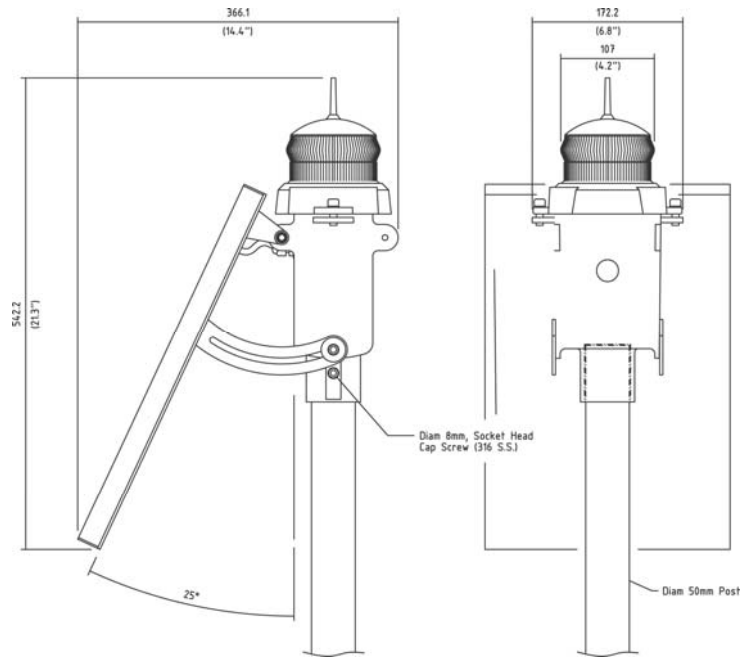

SL23 Model (fixed installation)

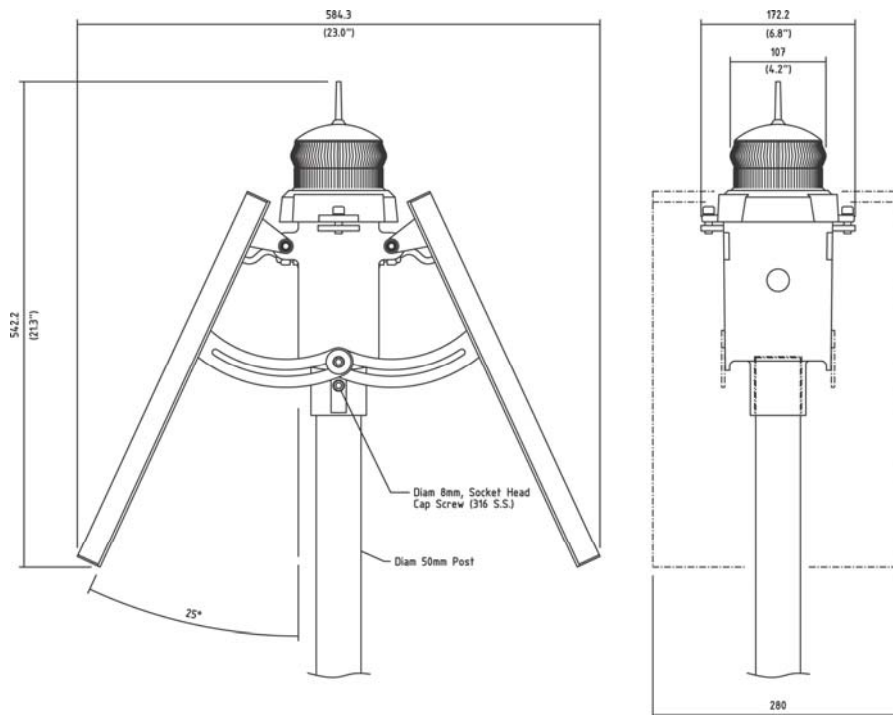

SL24 Model (buoy installation)



## Installation of all Models

Lantern is activated by connecting solar module and battery positive and negative wires. Intensity and flash settings need to be set prior to activation.

1. Unscrew the two socket cap screws located at either side of the lantern and remove lens cover.
2. Carefully remove internal flasher unit from within the lens cover.
3. The power and range settings of the lantern are adjusted by setting the DIP switches located on the top of this internal flasher unit. Your lantern is normally set to maximum range (see 'Selecting an Intensity Setting' below).
4. Set rotary switches to the required flash code (see 'Selecting a Flash Code' below), also located on the top of the internal flasher unit.
5. Replace internal flasher unit back inside lantern cover.
6. To activate the lantern, connect the "Battery Negative (-)" wire to the negative terminal, and the "Battery Positive (+)" wire to the positive terminal of the battery, and the "Solar Negative (-)" wire to internal "Solar Negative (-)" wire, and the "Solar Positive (+)" wire to the internal "Solar Positive (+)" wire.
7. Replace lens cover back onto unit, making sure that wires are not protruding, and screw the two socket cap screws up tight.
8. To test place dark cover (towel or jacket) on top of light to activate sensor, light will come on.

***Care must be taken to observe the polarity of each wire before they are connected. To ensure waterproofing of the unit, make sure that no wires are protruding and that there is an even seal when reattaching the lens cover to the unit body.***

### *Selecting an Intensity Setting*

Pulse settings on Sealite lanterns operate via DIP switches, located near the rotary switches on the flasher unit. The pulse settings may be used to reduce the power consumption and intensity of the lantern. Setting the lantern to 25% pulse will reduce the power consumption to 25% of the normal 100% setting and the range by 50%. This setting may be used to adjust to local sunlight conditions.

The following diagrams indicate pulse settings:-

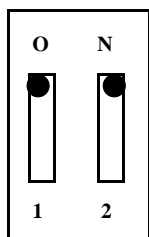

100%

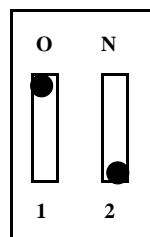

75%

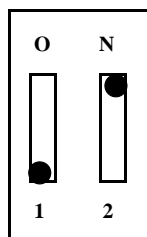

50%

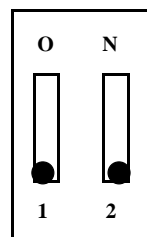

25%

### *Selecting a Flash Code- Rotary Switches A and B*

All lanterns have 2 rotary switches marked A and B on the flasher unit (see top of page 8). Turning the small arrows to the appropriate number or letter will set the code (see 'Flash Code' section, page 9). The unit may take up to one minute to activate a new flash code. A comprehensive list of available flash codes is listed on pages 9-15 of this manual.

## Rotary Switches A and B

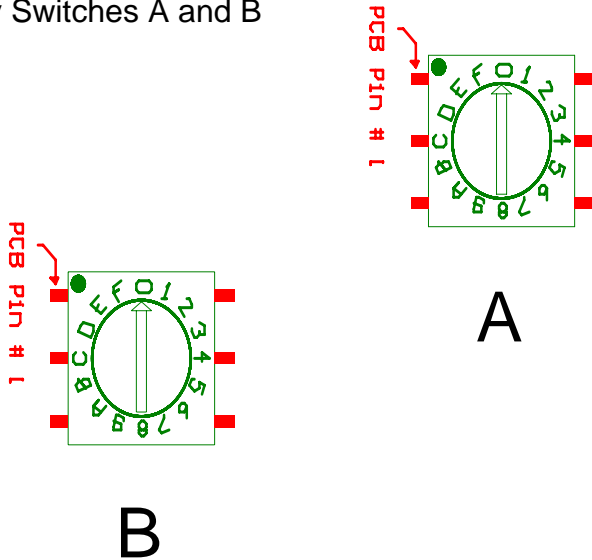

## Maintenance and Servicing

Designed to be maintenance free, the SL30, SL32, SL50, SL52, SL23 & SL24 require minimal attention, though the following maintenance and servicing information is provided to help ensure the life of your Sealite product.

1. Cleaning Solar Panels- occasional cleaning of the solar panels may be required. Using a cloth and warm soapy water, wipe off any foreign matter before rinsing the panels with fresh water.
2. Battery Check- inspection of batteries should be performed every three years (minimum) to ensure that the charger, battery and ancillary electronics are functioning correctly. Using a voltage meter, check that the battery voltage is at least 12 volts under 100MA load, and ensure all terminals are clear of foreign matter.

### Replacing the battery

The SL30, SL32, SL50, SL52, SL23 & SL24 lanterns have a sealed battery compartment, which provides the user with the ability to change the battery after years of operation.

1. Unscrew the two socket cap screws located at either side of the lantern and remove lens cover.
2. Disconnect the positive and negative wires from the battery.
3. Discard old battery in a safe manner.
4. Reattach positive and negative wires to the new battery and then place back into case.
5. Replace lens cover back onto unit, making sure that wires are not protruding, and screw two socket cap screws up tight.
6. To test place dark cover (towel or jacket) on top of light to activate sensor, light will come on.

***Care must be taken to observe the polarity of each wire before they are connected.  
To ensure waterproofing of the unit, make sure that no wires are protruding and that there is an even seal when reattaching the lens cover to the unit body.  
Always discard old batteries in a safe manner.***



## Flash Codes

SEALITE® code reference is listed by number of flashes. For the latest version of this document, check <http://www.sealite.com.au> or email [info@sealite.com.au](mailto:info@sealite.com.au)

### Symbols

FL	Flash followed by number Eg. FL 1 S, one flash every second	OC	Occulting; greater period on than off
F	Fixed	ISO	Isophase; equal period on and off
Q	Quick flash	LFL	Long flash long
VQ	Very quick flash	MO	Morse code ( ) contains letter

For example, VQ (6) + LFL 10 S means 6 very quick flashes followed by a long flash, during a 10-second interval.

### Duty Cycle

The amount of power your lantern draws through the night depends on the duty cycle, i.e. the amount of time ON as a proportion to the timing cycle (total time on and off). For example, 0.5 seconds ON and 4.5 seconds OFF equals a 10% duty cycle. It is best to operate at the lowest duty cycle appropriate to the actual needs of the application.

	Duty Cycle						
	10%	20%	30%	40%	50%	75%	100%
SL30	100%	75	75	75	50	25	25
SL32	100%	75	75	75	50	25	25
SL50	100%	100	100	100	50	25	25
SL52	100%	100	100	100	75	50	25
SL23.5	100%	100	100	100	50	25	25
SL23	100%	100	100	100	75	50	75
SL24.5	100%	100	100	100	75	50	25
SL24	100%	100	100	100	100	75	75

***Suggested DIP Setting (%) required to maintain operational autonomy.  
Based on 3hr average direct sunlight.***

### Recommended Rhythm for Flashing Light - IALA Regions A and B

MARK DESCRIPTION	RHYTHM
Port Hand & Starboard Marks:	Any, other than Composite Group Flashing (2+1)
Preferred Channel Starboard:	Composite Group Flashing (2+1)
Preferred Channel Port:	Composite Group Flashing (2+1)
North Cardinal Mark:	Very quick or quick
East Cardinal Mark:	Very quick (3) every 5 seconds or quick (3) every 10 seconds
South Cardinal Mark:	Very quick (6) + long flash every 10 seconds or quick (6) + long flash every 15 seconds
West Cardinal Mark:	Very quick (9) every 10 seconds or quick (9) every 15 seconds
Isolated Danger Mark:	Group flashing (2)
Safe Water Mark:	Isophase, occulting, one long flash every 10 seconds or Morse Code "A"
Special Marks:	Any, other than those described for Cardinal, Isolated Danger or Safe Water Marks



SWITCH		FLASH CODE	ON	OFF
A	B			
0	0	F (Steady light)		
D	3	VQ 0.5 S	0.2	0.3
E	3	VQ 0.6 S	0.2	0.4
F	3	VQ 0.6 S	0.3	0.3
7	3	Q 1 S	0.2	0.8
8	3	Q 1 S	0.3	0.7
9	3	Q 1 S	0.4	0.6
A	3	Q 1 S	0.5	0.5
8	4	Q 1 S	0.8	0.2
B	3	Q 1.2 S	0.3	0.9
9	4	Q 1.2 S	0.5	0.7
C	3	Q 1.2 S	0.6	0.6
F	4	FL 1.5 S	0.2	1.3
1	0	FL 1.5 S	0.3	1.2
0	5	FL 1.5 S	0.4	1.1
0	4	FL 1.5 S	0.5	1.0
2	0	FL 2 S	0.2	1.8
3	0	FL 2 S	0.3	1.7
4	0	FL 2 S	0.4	1.6
5	0	FL 2 S	0.5	1.5
6	0	FL 2 S	0.7	1.3
7	0	FL 2 S	0.8	1.2
1	2	ISO 2 S	1.0	1.0
8	0	FL 2.5 S	0.3	2.2
9	0	FL 2.5 S	0.5	2.0
D	6	FL 2.5 S	1.0	1.5
1	5	FL 3 S	0.2	2.8
A	0	FL 3 S	0.3	2.7
2	5	FL 3 S	0.4	2.6
B	0	FL 3 S	0.5	2.5
3	5	FL 3 S	0.6	2.4
C	0	FL 3 S	0.7	2.3
D	0	FL 3 S	1.0	2.0
2	2	ISO 3 S	1.5	1.5
5	4	OC 3 S	2.0	1.0
E	2	OC 3 S	2.5	0.5
4	6	OC 3.5 S	2.5	1.0
4	5	FL 4 S	0.2	3.8
5	5	FL 4 S	0.3	3.7
E	0	FL 4 S	0.4	3.6
F	0	FL 4 S	0.5	3.5
6	5	FL 4 S	0.6	3.4
0	1	FL 4 S	0.8	3.2
1	1	FL 4 S	1.0	3.0
2	1	FL 4 S	1.5	2.5
3	2	ISO 4 S	2.0	2.0
3	6	OC 4 S	2.5	1.5
F	2	OC 4 S	3.0	1.0
3	1	FL 4.3 S	1.3	3.0
8	5	FL 5 S	0.2	4.8
4	1	FL 5 S	0.3	4.7
5	1	FL 5 S	0.5	4.5
9	5	FL 5 S	0.9	4.1
6	1	FL 5 S	1.0	4.0
7	1	FL 5 S	1.5	3.5
4	2	ISO 5 S	2.5	2.5
8	2	LFL 5 S	2.0	3.0
0	3	OC 5 S	3.0	2.0



SWITCH		FLASH CODE	ON	OFF
A	B			
1	3	OC 5 S	4.0	1.0
2	3	OC 5 S	4.5	0.5
C	6	FL 6 S	0.2	5.8
B	5	FL 6 S	0.3	5.7
C	5	FL 6 S	0.4	5.6
8	1	FL 6 S	0.5	5.5
9	1	FL 6 S	0.6	5.4
A	1	FL 6 S	1.0	5.0
7	5	FL 6 S	1.2	4.8
B	1	FL 6 S	1.5	4.5
5	2	ISO 6 S	3.0	3.0
9	2	LFL 6 S	2.0	4.0
6	4	OC 6 S	4.0	2.0
3	3	OC 6 S	4.5	1.5
4	3	OC 6 S	5.0	1.0
A	4	FL 7 S	1.0	6.0
9	6	FL 7 S	2.0	5.0
5	6	OC 7 S	4.5	2.5
D	5	FL 7.5 S	0.5	7.0
C	1	FL 7.5 S	0.8	6.7
E	5	FL 8 S	0.5	7.5
B	4	FL 8 S	1.0	7.0
6	2	ISO 8 S	4.0	4.0
A	2	LFL 8 S	2.0	6.0
6	6	OC 8 S	5.0	3.0
B	2	LFL 8 S	3.0	5.0
F	5	FL 9 S	0.9	8.1
C	4	FL 9 S	1.0	8.0
7	6	OC 9 S	6.0	3.0
0	6	FL 10 S	0.2	9.8
1	6	FL 10 S	0.3	9.7
D	1	FL 10 S	0.5	9.5
2	6	FL 10 S	0.8	9.2
E	1	FL 10 S	1.0	9.0
1	4	FL 10 S	1.5	8.5
C	2	LFL 10 S	2.0	8.0
D	2	LFL 10 S	3.0	7.0
7	2	ISO 10 S	5.0	5.0
2	4	LFL 10 S	4.0	6.0
8	6	OC 10 S	6.0	4.0
5	3	OC 10 S	7.0	3.0
6	3	OC 10 S	7.5	2.5
F	1	FL 12 S	1.2	10.8
D	4	FL 12 S	2.5	9.5
3	4	LFL 12 S	2.0	10.0
0	2	FL 15 S	1.0	14.0
4	4	LFL 15 S	4.0	11.0
7	4	OC 15 S	10.0	5.0
A	6	LFL 20 S	2.0	18.0
E	4	FL 26 S	1.0	25.0



SWITCH		FLASH CODE	ON	OFF	ON	OFF
A	B					
0	A	FL (2) 4 S	0.5	1.0	0.5	2.0
E	B	VQ (2) 4 S	0.2	1.0	0.2	2.6
1	A	FL (2) 4.5 S	0.3	1.0	0.3	2.9
2	A	FL (2) 4.5 S	0.4	1.0	0.4	2.7
3	A	FL (2) 4.5 S	0.5	1.0	0.5	2.5
F	9	FL (2) 5 S	0.2	0.8	0.2	3.8
2	C	FL (2) 5 S	0.2	1.2	0.2	3.4
4	A	FL (2) 5 S	0.4	0.6	0.4	3.6
0	7	FL (2) 5 S	0.5	1.0	0.5	3.0
1	7	FL (2) 5 S	1.0	1.0	1.0	2.0
9	B	Q (2) 5 S	0.3	0.7	0.3	3.7
2	9	Q (2) 5 S	0.5	0.5	0.5	3.5
5	A	FL (2) 5.5 S	0.4	1.4	0.4	3.3
7	8	FL (2) 6 S	0.3	0.6	1.0	4.1
A	A	FL (2) 6 S	0.3	0.9	0.3	4.5
6	A	FL (2) 6 S	0.3	1.0	0.3	4.4
7	A	FL (2) 6 S	0.4	1.0	0.4	4.2
9	9	FL (2) 6 S	0.5	1.0	0.5	4.0
2	8	FL (2) 6 S	0.8	1.2	0.8	3.2
3	7	FL (2) 6 S	1.0	1.0	1.0	3.0
3	9	Q (2) 6 S	0.3	0.7	0.3	4.7
A	9	FL (2) 7 S	1.0	1.0	1.0	4.0
7	B	FL (2) 8 S	0.4	0.6	2.0	5.0
8	A	FL (2) 8 S	0.4	1.0	0.4	6.2
4	7	FL (2) 8 S	0.5	1.0	0.5	6.0
8	8	FL (2) 8 S	0.8	1.2	2.4	3.6
5	7	FL (2) 8 S	1.0	1.0	1.0	5.0
4	C	OC (2) 8 S	3.0	2.0	1.0	2.0
5	C	OC (2) 8 S	5.0	1.0	1.0	1.0
F	B	VQ (2) 8 S	0.2	1.0	0.2	6.6
9	A	FL (2) 10 S	0.4	1.6	0.4	7.6
9	8	FL (2) 10 S	0.5	0.5	1.5	7.5
6	7	FL (2) 10 S	0.5	1.0	0.5	8.0
7	7	FL (2) 10 S	0.5	1.5	0.5	7.5
6	9	FL (2) 10 S	0.5	2.0	0.5	7.0
8	7	FL (2) 10 S	0.8	1.2	0.8	7.2
B	9	FL (2) 10 S	1.0	1.0	1.0	7.0
9	7	FL (2) 10 S	1.0	1.5	1.0	6.5
4	9	Q (2) 10 S	0.6	0.4	0.6	8.4
B	A	FL (2) 12 S	0.4	1.0	0.4	10.2
C	9	FL (2) 12 S	0.5	1.0	0.5	10.0
D	9	FL (2) 12 S	1.5	2.0	1.5	7.0
A	8	FL (2) 15 S	0.5	1.5	2.0	11.0
A	7	FL (2) 15 S	1.0	2.0	1.0	11.0
8	B	Q (2) 15 S	0.2	0.8	0.2	13.8
C	A	FL (2) 20 S	1.0	3.0	1.0	15.0
D	A	FL (2) 25 S	1.0	1.0	1.0	22.0



SWITCH	FLASH CODE	ON	OFF	ON	OFF	ON	OFF
A	B						
7	9	Q (3) 5 S	0.5	0.5	0.5	0.5	2.5
5	9	VQ (3) 5 S	0.2	0.3	0.2	0.3	3.8
0	C	VQ (3) 5 S	0.3	0.2	0.3	0.2	3.7
E	9	VQ (3) 5 S	0.3	0.3	0.3	0.3	3.5
3	C	FL (3) 6 S	0.5	1.0	0.5	1.0	2.5
2	B	FL (2+1) 6 S	0.3	0.4	0.3	1.2	3.5
A	B	Q (3) 6 S	0.3	0.7	0.3	0.7	3.7
F	A	FL (3) 8 S	0.5	1.0	0.5	1.0	4.5
0	B	FL (3) 9 S	0.3	1.0	0.3	1.0	6.1
B	7	FL (3) 9 S	0.8	1.2	0.8	1.2	4.2
B	8	FL (3) 10 S	0.3	0.7	0.3	0.7	7.1
C	8	FL (3) 10 S	0.4	0.6	0.4	0.6	6.8
C	B	FL (3) 10 S	0.5	0.5	0.5	0.5	7.5
C	7	FL (3) 10 S	0.5	1.5	0.5	1.5	5.5
D	B	FL (3) 10 S	0.6	0.6	0.6	0.6	7.0
D	7	FL (3) 10 S	1.0	1.0	1.0	1.0	5.0
3	8	FL (2+1) 10 S	0.5	0.7	0.5	2.1	5.7
8	9	OC (3) 10 S	5.0	1.0	1.0	1.0	1.0
B	B	Q (3) 10 S	0.3	0.7	0.3	0.7	7.7
D	8	FL (2 + 1) 10 S	0.5	0.5	0.5	0.5	6.5
1	B	FL (3) 12 S	0.5	1.5	0.5	1.5	7.5
E	A	FL (3) 12 S	0.5	2.0	0.5	2.0	6.5
E	7	FL (3) 12 S	0.8	1.2	0.8	1.2	7.2
B	6	FL (3) 12 S	1.0	1.0	1.0	3.0	5.0
4	8	FL (2+1) 12 S	0.8	1.2	0.8	2.4	6.0
5	8	FL (2+1) 12 S	1.0	1.0	1.0	4.0	4.0
1	8	FL (2+1) 13.5 S	1.0	1.0	1.0	4.0	5.5
F	7	FL (3) 15 S	0.3	1.7	0.3	1.7	10.7
9	D	FL (3) 15 S	0.4	1.0	0.4	1.0	11.8
0	8	FL (3) 15 S	0.5	1.5	0.5	1.5	10.5
F	8	FL (2+1) 15 S	0.6	0.3	0.6	0.3	11.8
0	9	FL (2+1) 15 S	0.7	0.5	0.7	0.5	10.7
1	9	FL (2+1) 15 S	0.7	0.7	0.7	0.7	10.1
6	8	FL (2+1) 15 S	1.0	2.0	1.0	5.0	5.0
1	C	VQ (3) 15 S	0.1	0.5	0.1	0.5	13.7
4	B	FL (3) 20 S	0.5	3.0	0.5	3.0	12.5
3	B	FL (3) 20 S	0.5	1.5	0.5	1.5	15.5
5	B	FL (3) 20 S	0.8	1.2	0.8	1.2	15.2
6	B	FL (3) 20 S	1.0	1.0	1.0	1.0	15.0



SWITCH	FLASH CODE	ON	OFF	ON	OFF	ON	OFF	ON	OFF	ON	OFF
A	B										
B	F	VQ (4) 4 S	0.25	0.25	0.25	0.25	0.25	0.25	0.25	0.25	2.25
B	D	Q (4) 6 S	0.3	0.7	0.3	0.7	0.3	0.7	0.3	0.7	2.7
8	D	Q (4) 6 S	0.4	0.6	0.4	0.6	0.4	0.6	0.4	0.6	2.6
1	D	FL (4) 10 S	0.5	1.0	0.5	1.0	0.5	1.0	0.5	1.0	5.0
2	D	FL (4) 10 S	0.8	1.2	0.8	1.2	0.8	1.2	0.8	1.2	3.2
F	E	Q (4) 10 S	0.3	0.7	0.3	0.7	0.3	0.7	0.3	0.7	6.7
B	E	FL (4) 12 S	0.3	1.7	0.3	1.7	0.3	1.7	0.3	1.7	5.7
4	F	FL (4) 12 S	0.5	0.5	0.5	0.5	0.5	0.5	0.5	0.5	8.5
C	E	FL (4) 12 S	0.5	1.5	0.5	1.5	0.5	1.5	0.5	1.5	5.5
3	D	FL (4) 12 S	0.8	1.2	0.8	1.2	0.8	1.2	0.8	1.2	5.2
A	D	Q (4) 12 S	0.3	0.7	0.3	0.7	0.3	0.7	0.3	0.7	8.7
4	D	FL (4) 15 S	0.5	1.5	0.5	1.5	0.5	1.5	0.5	1.5	8.5
8	E	FL (4) 15 S	1.0	1.0	1.0	1.0	1.0	1.0	1.0	1.0	8.0
7	D	FL (4) 15 S	1.5	0.5	0.5	0.5	0.5	0.5	0.5	0.5	10.5
D	E	FL (4) 16 S	0.5	1.5	0.5	1.5	0.5	1.5	0.5	1.5	9.5
C	D	FL (4) 20 S	0.3	3.0	0.3	3.0	0.3	3.0	0.3	3.0	9.8
5	D	FL (4) 20 S	0.5	1.5	0.5	1.5	0.5	1.5	0.5	1.5	13.5
0	D	FL (4) 20 S	0.5	1.5	0.5	1.5	0.5	4.5	0.5	4.5	10.5
3	F	FL (4) 20 S	1.5	1.5	1.5	1.5	1.5	1.5	1.5	1.5	9.5
0	F	Q (4) 20 S	0.5	0.5	0.5	0.5	0.5	0.5	0.5	0.5	16.5
E	E	Q (4) 28 S	0.5	0.5	0.5	0.5	0.5	0.5	0.5	0.5	24.5
6	F	FL (4) 30 S	0.5	0.5	0.5	0.5	0.5	0.5	0.5	0.5	26.5

SWITCH	FLASH CODE	ON	OFF	ON	OFF	ON	OFF	ON	OFF	ON	OFF
A	B										
D	D	Q (5) 7 S	0.3	0.7	0.3	0.7	0.3	0.7	0.3	0.7	2.7
E	D	Q (5) 10 S	0.3	0.7	0.3	0.7	0.3	0.7	0.3	0.7	5.7
E	8	FL (5) 16.5 S	5.0	1.5	0.5	1.5	0.5	1.5	0.5	1.5	3.5
5	F	FL (5) 20 S	0.5	0.5	0.5	0.5	0.5	0.5	0.5	0.5	15.5
9	F	FL (5) 20 S	0.8	1.2	0.8	1.2	0.8	1.2	0.8	1.2	11.2
9	E	FL (5) 20 S	1.0	1.0	1.0	1.0	1.0	1.0	1.0	1.0	11.0

SWITCH	FLASH CODE	ON	OFF	ON	OFF	ON	OFF	ON	OFF	ON	OFF	ON	OFF
A	B												
F	D	Q (6) 10 S	0.3	0.7	0.3	0.7	0.3	0.7	0.3	0.7	0.3	0.7	4.7
A	F	FL (6) 15 S	0.3	0.7	0.3	0.7	0.3	0.7	0.3	0.7	0.3	0.7	9.7
7	F	FL (6) 15 S	0.5	1.0	0.5	1.0	0.5	1.0	0.5	1.0	0.5	1.0	7.0
A	E	FL (6) + LFL 15 S	0.5	1.0	0.5	1.0	0.5	1.0	0.5	1.0	0.5	1.0	7.0

SWITCH	FLASH CODE	ON	OFF	ON	OFF	ON	OFF	ON	OFF	ON	OFF	ON	OFF	ON	OFF	
A	B															
6	E	VQ (6) + LFL 10 S	0.2	0.3	0.2	0.3	0.2	0.3	0.2	0.3	0.2	0.3	0.2	0.3	2.0	5.0
7	E	VQ (6) + LFL 10 S	0.3	0.3	0.3	0.3	0.3	0.3	0.3	0.3	0.3	0.3	0.3	0.3	2.0	4.4
2	F	Q (6) + LFL 15 S	0.2	0.8	0.2	0.8	0.2	0.8	0.2	0.8	0.2	0.8	0.2	0.8	2.0	7.0
2	E	Q (6) + LFL 15 S	0.3	0.7	0.3	0.7	0.3	0.7	0.3	0.7	0.3	0.7	0.3	0.7	2.0	7.0
3	E	Q (6) + LFL 15 S	0.6	0.6	0.6	0.6	0.6	0.6	0.6	0.6	0.6	0.6	0.6	0.6	2.0	5.8
8	F	VQ (6) + LFL 15 S	0.3	0.3	0.3	0.3	0.3	0.3	0.3	0.3	0.3	0.3	0.3	0.3	2.0	9.4

SWITCH	FLASH CODE	ON	OFF	ON	OFF	ON	OFF	ON	OFF	ON	OFF	ON	OFF	ON	OFF	ON	OFF	ON	OFF	
A	B																			
4	E	VQ (9) 10 S	0.2	0.3	0.2	0.3	0.2	0.3	0.2	0.3	0.2	0.3	0.2	0.3	0.2	0.3	0.2	0.3	0.2	5.8
5	E	VQ (9) 10 S	0.3	0.3	0.3	0.3	0.3	0.3	0.3	0.3	0.3	0.3	0.3	0.3	0.3	0.3	0.3	0.3	0.3	4.9
1	F	Q (9) 15 S	0.2	0.8	0.2	0.8	0.2	0.8	0.2	0.8	0.2	0.8	0.2	0.8	0.2	0.8	0.2	0.8	0.2	6.8
0	E	Q (9) 15 S	0.3	0.7	0.3	0.7	0.3	0.7	0.3	0.7	0.3	0.7	0.3	0.7	0.3	0.7	0.3	0.7	0.3	6.7
1	E	Q (9) 15 S	0.6	0.6	0.6	0.6	0.6	0.6	0.6	0.6	0.6	0.6	0.6	0.6	0.6	0.6	0.6	0.6	0.6	4.8



SWITCH	FLASH CODE	ON	OFF	ON	OFF	ON	OFF	ON	OFF
A	B								
MORSE CODE ( ) INDICATES LETTER									
7	8	MO (A) 6 S	0.3	0.6	1.0	4.1			
7	B	MO (A) 8 S	0.4	0.6	2.0	5.0			
8	8	MO (A) 8 S	0.8	1.2	2.4	3.6			
B	8	MO (U) 10 S	0.3	0.7	0.3	0.7	0.9	7.1	
C	8	MO (U) 10 S	0.4	0.6	0.4	0.6	1.2	6.8	
D	8	MO (U) 10 S	0.5	0.5	0.5	0.5	1.5	6.5	
9	8	MO (A) 10 S	0.5	0.5	1.5	7.5			
8	9	MO (D) 10 S	5.0	1.0	1.0	1.0	1.0	1.0	
A	8	MO (A) 15 S	0.5	1.5	2.0	11.0			
F	8	MO (U) 15 S	0.6	0.3	0.6	0.3	1.4	11.8	
0	9	MO (U) 15 S	0.7	0.5	0.7	0.5	1.9	10.7	
1	9	MO (U) 15 S	0.7	0.7	0.7	0.7	2.1	10.1	
7	D	MO (B) 15 S	1.5	0.5	0.5	0.5	0.5	0.5	0.5 10.5

## Trouble Shooting

### Problem

### Remedy

Lantern will not activate.	<ul style="list-style-type: none"> <li>• Ensure lantern is in darkness.</li> <li>• Wait at least 60 seconds for the program to initialise in darkness.</li> <li>• Ensure switch setting is on a valid code (not unused flash code).</li> <li>• Ensure battery terminals are properly connected.</li> <li>• Ensure battery voltage is above 12volts.</li> </ul>
Timing codes will not change.	<ul style="list-style-type: none"> <li>• Turn rotary switches several times to ensure contacts are clear.</li> </ul>
Lantern will not operate for the entire night.	<ul style="list-style-type: none"> <li>• Expose lantern to direct sunlight and monitor operation for several days. Sealite products typically require 1.5 hours of direct sunlight per day to retain full autonomy. From a discharged state, the lantern may require several days of operational conditions to 'cycle' up to full autonomy.</li> <li>• Reducing the light output intensity or duty cycle (flash code) will reduce current draw on the battery.</li> <li>• Ensure solar module is clean and not covered by shading during the day.</li> </ul>



## Sealite Lantern Warranty

### *Activating the warranty*

Upon purchase, the Sealite warranty must be activated for recognition of future claims. To do this you have two (2) options:

1. Postal registration
  - Please complete the Sealite Warranty Registration card and return to Sealite within 30 days of your purchase.
  
2. Online registration
  - Please complete the Online Registration form at;

[www.sealite.com.au](http://www.sealite.com.au) or [www.sealiteusa.com](http://www.sealiteusa.com)

Sealite Pty. Ltd. will repair or replace your lantern in the event of electronic failure for a period of three years from the date of purchase.

The unit must be returned to Sealite Pty. Ltd. freight prepaid.

### Warranty Conditions

1. The warranty is applicable to lanterns manufactured from 1/1/2000.
2. The lantern must be installed in accordance with Sealite instructions.
3. No modifications to the original specifications determined by Sealite shall be made without written approval of Sealite Pty. Ltd.
4. Input voltage shall not exceed those recommended for the product.
5. Warranty does not cover damage caused by the incorrect replacement of battery in the SL15, SL60 or SL70 lantern models.
6. Replacement of battery is excluded from the warranty.
7. No recognition shall be given to flooding, or damage incurred from misuse of lanterns.
8. Solar modules are covered by individual manufacturers' warranty.

Information in this manual is subject to change without notice and does not represent a commitment on the part of the vendor. Sealite products are subject to certain Australian and world-wide patent applications.



#### **Head Office**

Sealite Pty Ltd  
11 Industrial Drive  
Somerville, Vic 3912  
Australia  
Tel: +61 3 5977 6128  
Fax: +61 3 5977 6124  
Email: [info@sealite.com.au](mailto:info@sealite.com.au)  
Internet: [www.sealite.com.au](http://www.sealite.com.au)

#### **USA Customers**

Sealite USA  
29 Gilford East Drive  
Gilford, NH 03249  
USA  
Tel: (603) 524-6066  
Fax: (603) 524-8100  
Email: [info@sealiteusa.com](mailto:info@sealiteusa.com)  
Internet: [www.sealiteusa.com](http://www.sealiteusa.com)