



SL07 & SL10 Installation and Service Manual

Version 3.1



Table of Contents

Introduction	2
Operating Principle	3
Technology	3
SL07 Model	4
SL10 Model	6
Maintenance & Servicing	7
Flash Codes	8
Troubleshooting	14
Sealite Lantern Warranty	15

Introduction

Congratulations! By choosing to purchase a Sealite lantern you have become the owner of one of the most advanced LED marine lanterns in the world.

Sealite Pty Ltd has been manufacturing lanterns for over 20 years, and particular care has been taken to ensure your lantern gives years of service.

As a commitment to producing the highest quality products for our customers, Sealite has been independently certified as complying with the requirements of **ISO 9001:2000** quality management system.

By taking a few moments to browse through this booklet, you will become familiar with the versatility of your lantern, and be able to maximise its operating function.

Please remember to complete the Sealite warranty registration card accompanying your lantern.



Operating Principle

The SL07 and SL10 are designed to operate in conjunction with existing or purpose-built power supplies (battery or mains connection).

The flasher unit has very low current requirements. A microprocessor drives an array of ultra bright LED's through a DC/DC converter, which enables the LED's to operate within the manufacturer's specifications.

On darkness, the microprocessor will initiate a program check and after approximately 1 minute begin flashing to the set code.

Technology

Electronics

Sealite employs leading in-house electronic engineers in the design and development of software and related circuitry. All individual electronic components are sourced directly by Sealite procurement staff ensuring that only the highest quality components are used in our products.

LED Technology

All marine lanterns use the latest advancements in LED (Light Emitting Diode) technology as a light source. The major advantage of LED's over traditional light sources is well established in that they typically have an operational life in excess of 100,000 hours, resulting in substantial savings to maintenance and servicing costs.

Precision Construction

Commitment to investing in the design and construction of injection-moulded parts including optic lenses, light bases and a range of other components ensures that all Sealite products are of a consistent and superior quality.

Optical Performance

Sealite manufactures a range of marine LED lenses moulded from multi-cavity dies. Complex shapes such as the SL70 lens are a testament to the company's superior in-house lens manufacturing capabilities and outstanding optical performance.

Award-winning, Patented Technology

Several United States and Australian patent registrations are held on Sealite's range of innovative designs, with other regional patents pending in Canada, United Kingdom and Europe.



SL07 Model

The SL07 LED light fixture is designed to offer superior visibility and operate in conjunction with existing or purpose-built power supplies. With a variable range of 1-4nm, a maintenance-free light source, and choice of up to 256 user-adjustable flash codes, the SL07 is available in a number of configurations, colours and cable lengths and is the preferred replacement for obsolete incandescent lights.

An optional ON/OFF switch can be also installed on request (additional charges may apply).

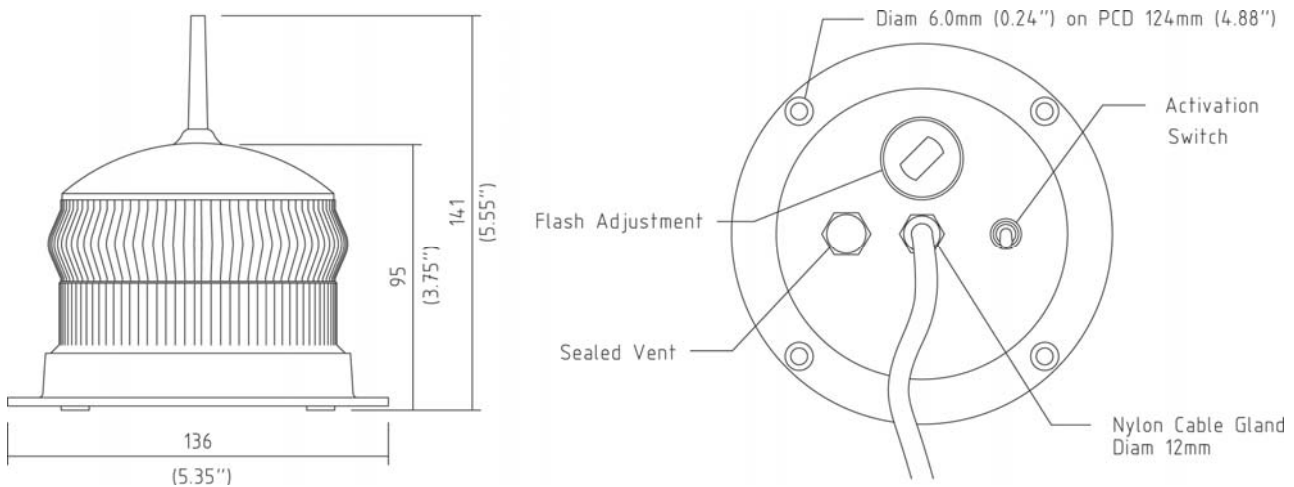

See page 6 for Specifications Table.

Installation of SL07 Model

Lantern is activated by optional ON/OFF Switch, or connection of positive and negative wires to battery or mains system. Flash setting needs to be set prior to activation.

1. Remove the marked flash adjustment bung from the base of the lantern and set rotary switches to the required flash code (see 'Selecting a Flash Code', page 5).
2. Replace flash adjustment bung.
3. A sealed vent on the base allows air transfer without moisture intake, and should not be disturbed.
4. **Battery Connection:** Connect "Battery Negative (-)" wire to negative terminal of battery, and "Battery Positive (+)" wire to positive terminal of battery.
Mains Connection: Connect negative and then positive wires to 12volt power supply (ONLY).
5. To test place dark cover (towel or jacket) on top of light to activate sensor, light will come on.
6. Ensure that the unit is bolted to an even, flat surface.

Care must be taken to observe the polarity of each wire before they are connected.



Intensity Setting

Intensity options are available for the Sealite SL07 model, but must be preset during manufacturing.

Selecting a Flash Code- Rotary Switches A and B

All lanterns have 2 rotary switches marked A and B on the flasher unit (see below). Turning the small arrows to the appropriate number or letter will set the code (see 'Flash Code' section, page 9). The unit may take up to one minute to activate a new flash code. A comprehensive list of available flash codes is listed on pages 9-15 of this manual.

Rotary Switches A and B



SL10 Model

The heavy-duty SL10 LED light fixture with a variable range of 1 to 4nm is designed to operate in conjunction with existing or purpose-built power supplies, and offers maintenance-free service over a wide range of environmental conditions. Available in a number of configurations, colours and cable lengths, the SL10 is the perfect replacement for obsolete incandescent lights in extreme environments.

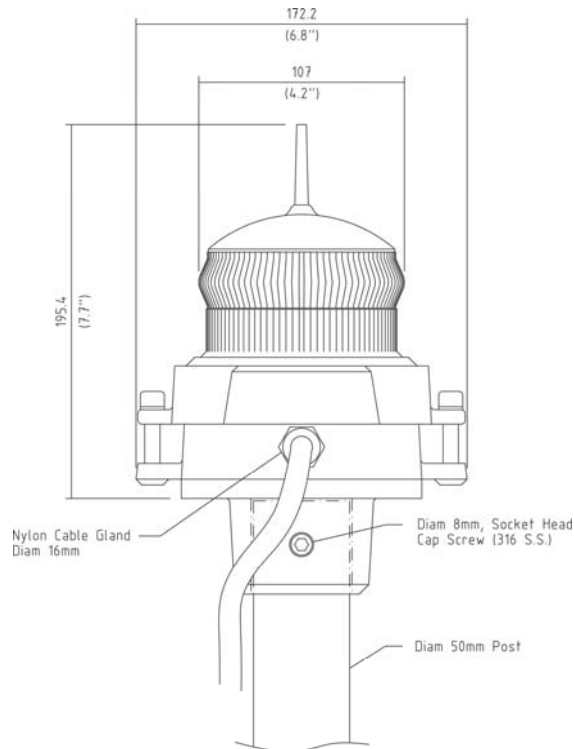

SL07 and SL10 Specifications -

Model		Description	Intensity (peak)	Colour	No. LEDs	Power Amp/hour	Voltage
SL07-1.R	SL10-1.R	1nm LED Light Head	1.5cd	Red	10	0.009	12v
SL07-1.G	SL10-1.G		1.5cd	Green	10	0.009	12v
SL07-1.W	SL10-1.W		1.3cd	White	10	0.009	12v
SL07-1.Y	SL10-1.Y		1.4cd	Yellow	10	0.009	12v
SL07-2.R	SL10-2.R	2nm LED Light Head	7cd	Red	10	0.035	12v
SL07-2.G	SL10-2.G		7cd	Green	10	0.035	12v
SL07-2.W	SL10-2.W		5cd	White	10	0.035	12v
SL07-2.Y	SL10-2.Y		6cd	Yellow	10	0.035	12v
SL07-3.R	SL10-3.R	3nm LED Light Head	23cd	Red	20	0.120	12v
SL07-3.G	SL10-3.G		23cd	Green	20	0.120	12v
SL07-3.W	SL10-3.W		17cd	White	20	0.120	12v
SL07-3.Y	SL10-3.Y		19cd	Yellow	20	0.120	12v
SL07-4.R	SL10-4.R	4nm LED Light Head	45cd	Red	20	0.220	12v
SL07-4.G	SL10-4.G		46cd	Green	20	0.220	12v
SL07-4.W	SL10-4.W		41cd	White	20	0.220	12v
SL07-4.Y	SL10-4.Y		43cd	Yellow	20	0.220	12v

- Specifications subject to change or variation without notice



Order Codes (for products in specifications table, page 6)

- FX: Fixed light on power-up.
- FL: Flashing or steady light on power-up. Excludes photodiode. 24hr operation. 256 IALA adjustable flash rates.
- FL-S: Flashing or steady light on darkness. Includes photodiode for automatic darkness activation. 256 IALA adjustable flash rates.

Eg. SL07-3.B-FL-S: denotes 3nm SL07 light head BLUE c/w adjustable flash rates and photodiode.

Installation of SL10 Model

Lantern is activated by connection of positive and negative wires to battery or mains system. Intensity and flash settings need to be set prior to activation.

1. Unscrew the two socket cap screws located at either side of the lantern and remove lens cover.
2. Remove internal flasher unit from within the lens cover.
3. The power and range settings of the lantern are adjusted by setting the DIP switches located on the top of this internal flasher unit. Your lantern is normally set to maximum range (see 'Selecting an Intensity Setting', page 8).
4. Set rotary switches to the required flash code (see 'Selecting a Flash Code', page 8), also located on the top of the internal flasher unit.
5. Replace internal flasher unit back inside lantern cover.
6. Replace lens cover back onto unit, making sure that wires are not protruding, and screw the two socket cap screws up tight.
7. Battery Connection: Connect "Battery Negative (-)" wire to negative terminal of battery, and "Battery Positive (+)" wire to positive terminal of battery.
Mains Connection: Connect negative and then positive wires to 12volt power supply (ONLY).
8. To test place dark cover (towel or jacket) on top of light to activate sensor, light will come on.
9. Ensure that the unit is bolted to an even, flat surface.

Care must be taken to observe the polarity of each wire before they are connected. To ensure waterproofing of the unit, make sure that no wires are protruding and that there is an even seal when reattaching the lens cover to the unit body.



Selecting an Intensity Setting

Pulse settings on Sealite lanterns operate via DIP switches, located near the rotary switches on the flasher unit. The pulse settings may be used to reduce the power consumption and intensity of the lantern. Setting the lantern to 25% pulse will reduce the power consumption to 25% of the normal 100% setting and the range by 50%. This setting may be used to adjust to local sunlight conditions.

The following diagrams indicate pulse settings:-

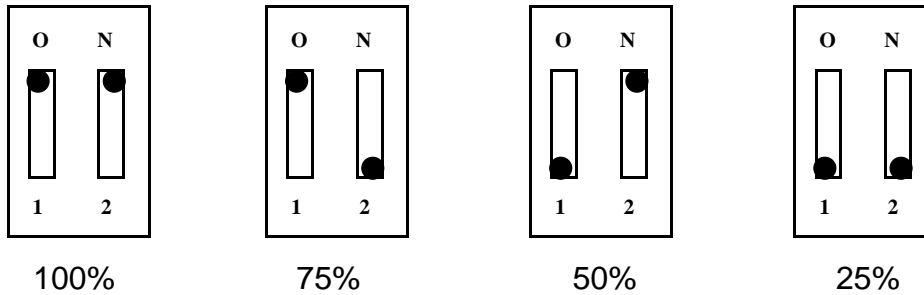

Selecting a Flash Code- Rotary Switches A and B

All lanterns have 2 rotary switches marked A and B on the flasher unit, as below. Turning the small arrows to the appropriate number or letter will set the code (see 'Flash Code' section, page 9). The unit may take up to one minute to activate a new flash code. A comprehensive list of available flash codes is listed on pages 9-15 of this manual.

Rotary Switches A and B

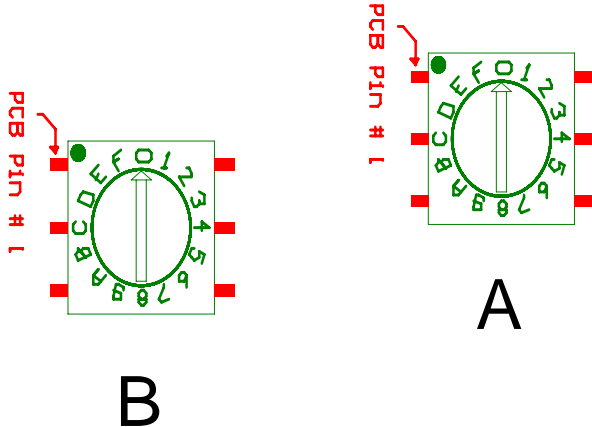

Maintenance and Servicing

Designed to be maintenance free, the SL07 & SL10 require minimal attention, though the following maintenance and servicing information is provided to help ensure the life of your product.

1. Cleaning Lens- occasional cleaning of the light lens may be required. Using a cloth and warm soapy water, wipe off any foreign matter before rinsing the lens with fresh water.
2. Battery Check- inspection of batteries should be performed every three years (minimum) to ensure that the charger, battery and ancillary electronics are functioning correctly. Using a voltage meter, check that the battery voltage is at least 12 volts under 100MA load, and ensure all terminals are clear of foreign matter (Battery Connected Units Only).



Flash Codes

SEALITE® code reference is listed by number of flashes

For the latest version of this document, check:

<http://www.sealite.com.au>

E-mail: info@sealite.com.au

Symbols

- FL Flash followed by number Eg. FL 1 S, one flash every second
- F Fixed
- Q Quick flash
- VQ Very quick flash
- OC Occulting; greater period on than off
- ISO Isophase; equal period on and off
- LFL Long flash long
- MO Morse code () contains letter

For example, VQ (6) + LFL 10 S means 6 very quick flashes followed by a long flash, during a 10-second interval.

The amount of power your lantern draws through the night depends on the duty cycle, i.e. the amount of time on as a proportion to the timing cycle. For example, 0.5 seconds on and 4.5 seconds off equals a 10% duty cycle.

It is best to operate at the lowest duty cycle appropriate to the actual needs of the application.

Recommended Rhythm for Flashing Light - IALA Regions A and B

MARK DESCRIPTION	RHYTHM
Port Hand & Starboard Marks:	Any, other than Composite Group Flashing (2+1)
Preferred Channel Starboard:	Composite Group Flashing (2+1)
Preferred Channel Port:	Composite Group Flashing (2+1)
North Cardinal Mark:	Very quick or quick
East Cardinal Mark:	Very quick (3) every 5 seconds or quick (3) every 10 seconds
South Cardinal Mark:	Very quick (6) + long flash every 10 seconds or quick (6) + long flash every 15 seconds
West Cardinal Mark:	Very quick (9) every 10 seconds or quick (9) every 15 seconds
Isolated Danger Mark:	Group flashing (2)
Safe Water Mark:	Isophase, occulting, one long flash every 10 seconds or Morse Code "A"
Special Marks:	Any, other than those described for Cardinal, Isolated Danger or Safe Water Marks



SWITCH		FLASH CODE	ON	OFF
A	B			
0	0	F (Steady light)		
D	3	VQ 0.5 S	0.2	0.3
E	3	VQ 0.6 S	0.2	0.4
F	3	VQ 0.6 S	0.3	0.3
7	3	Q 1 S	0.2	0.8
8	3	Q 1 S	0.3	0.7
9	3	Q 1 S	0.4	0.6
A	3	Q 1 S	0.5	0.5
8	4	Q 1 S	0.8	0.2
B	3	Q 1.2 S	0.3	0.9
9	4	Q 1.2 S	0.5	0.7
C	3	Q 1.2 S	0.6	0.6
F	4	FL 1.5 S	0.2	1.3
1	0	FL 1.5 S	0.3	1.2
0	5	FL 1.5 S	0.4	1.1
0	4	FL 1.5 S	0.5	1.0
2	0	FL 2 S	0.2	1.8
3	0	FL 2 S	0.3	1.7
4	0	FL 2 S	0.4	1.6
5	0	FL 2 S	0.5	1.5
6	0	FL 2 S	0.7	1.3
7	0	FL 2 S	0.8	1.2
1	2	ISO 2 S	1.0	1.0
8	0	FL 2.5 S	0.3	2.2
9	0	FL 2.5 S	0.5	2.0
D	6	FL 2.5 S	1.0	1.5
1	5	FL 3 S	0.2	2.8
A	0	FL 3 S	0.3	2.7
2	5	FL 3 S	0.4	2.6
B	0	FL 3 S	0.5	2.5
3	5	FL 3 S	0.6	2.4
C	0	FL 3 S	0.7	2.3
D	0	FL 3 S	1.0	2.0
2	2	ISO 3 S	1.5	1.5
5	4	OC 3 S	2.0	1.0
E	2	OC 3 S	2.5	0.5
4	6	OC 3.5 S	2.5	1.0
4	5	FL 4 S	0.2	3.8
5	5	FL 4 S	0.3	3.7
E	0	FL 4 S	0.4	3.6
F	0	FL 4 S	0.5	3.5
6	5	FL 4 S	0.6	3.4
0	1	FL 4 S	0.8	3.2
1	1	FL 4 S	1.0	3.0
2	1	FL 4 S	1.5	2.5
3	2	ISO 4 S	2.0	2.0
3	6	OC 4 S	2.5	1.5
F	2	OC 4 S	3.0	1.0
3	1	FL 4.3 S	1.3	3.0
8	5	FL 5 S	0.2	4.8
4	1	FL 5 S	0.3	4.7
5	1	FL 5 S	0.5	4.5
9	5	FL 5 S	0.9	4.1
6	1	FL 5 S	1.0	4.0
7	1	FL 5 S	1.5	3.5
4	2	ISO 5 S	2.5	2.5
8	2	LFL 5 S	2.0	3.0
0	3	OC 5 S	3.0	2.0



SWITCH		FLASH CODE	ON	OFF
A	B			
1	3	OC 5 S	4.0	1.0
2	3	OC 5 S	4.5	0.5
C	6	FL 6 S	0.2	5.8
B	5	FL 6 S	0.3	5.7
C	5	FL 6 S	0.4	5.6
8	1	FL 6 S	0.5	5.5
9	1	FL 6 S	0.6	5.4
A	1	FL 6 S	1.0	5.0
7	5	FL 6 S	1.2	4.8
B	1	FL 6 S	1.5	4.5
5	2	ISO 6 S	3.0	3.0
9	2	LFL 6 S	2.0	4.0
6	4	OC 6 S	4.0	2.0
3	3	OC 6 S	4.5	1.5
4	3	OC 6 S	5.0	1.0
A	4	FL 7 S	1.0	6.0
9	6	FL 7 S	2.0	5.0
5	6	OC 7 S	4.5	2.5
D	5	FL 7.5 S	0.5	7.0
C	1	FL 7.5 S	0.8	6.7
E	5	FL 8 S	0.5	7.5
B	4	FL 8 S	1.0	7.0
6	2	ISO 8 S	4.0	4.0
A	2	LFL 8 S	2.0	6.0
6	6	OC 8 S	5.0	3.0
B	2	LFL 8 S	3.0	5.0
F	5	FL 9 S	0.9	8.1
C	4	FL 9 S	1.0	8.0
7	6	OC 9 S	6.0	3.0
0	6	FL 10 S	0.2	9.8
1	6	FL 10 S	0.3	9.7
D	1	FL 10 S	0.5	9.5
2	6	FL 10 S	0.8	9.2
E	1	FL 10 S	1.0	9.0
1	4	FL 10 S	1.5	8.5
C	2	LFL 10 S	2.0	8.0
D	2	LFL 10 S	3.0	7.0
7	2	ISO 10 S	5.0	5.0
2	4	LFL 10 S	4.0	6.0
8	6	OC 10 S	6.0	4.0
5	3	OC 10 S	7.0	3.0
6	3	OC 10 S	7.5	2.5
F	1	FL 12 S	1.2	10.8
D	4	FL 12 S	2.5	9.5
3	4	LFL 12 S	2.0	10.0
0	2	FL 15 S	1.0	14.0
4	4	LFL 15 S	4.0	11.0
7	4	OC 15 S	10.0	5.0
A	6	LFL 20 S	2.0	18.0
E	4	FL 26 S	1.0	25.0



SWITCH		FLASH CODE	ON	OFF	ON	OFF
A	B					
0	A	FL (2) 4 S	0.5	1.0	0.5	2.0
E	B	VQ (2) 4 S	0.2	1.0	0.2	2.6
1	A	FL (2) 4.5 S	0.3	1.0	0.3	2.9
2	A	FL (2) 4.5 S	0.4	1.0	0.4	2.7
3	A	FL (2) 4.5 S	0.5	1.0	0.5	2.5
F	9	FL (2) 5 S	0.2	0.8	0.2	3.8
2	C	FL (2) 5 S	0.2	1.2	0.2	3.4
4	A	FL (2) 5 S	0.4	0.6	0.4	3.6
0	7	FL (2) 5 S	0.5	1.0	0.5	3.0
1	7	FL (2) 5 S	1.0	1.0	1.0	2.0
9	B	Q (2) 5 S	0.3	0.7	0.3	3.7
2	9	Q (2) 5 S	0.5	0.5	0.5	3.5
5	A	FL (2) 5.5 S	0.4	1.4	0.4	3.3
7	8	FL (2) 6 S	0.3	0.6	1.0	4.1
A	A	FL (2) 6 S	0.3	0.9	0.3	4.5
6	A	FL (2) 6 S	0.3	1.0	0.3	4.4
7	A	FL (2) 6 S	0.4	1.0	0.4	4.2
9	9	FL (2) 6 S	0.5	1.0	0.5	4.0
2	8	FL (2) 6 S	0.8	1.2	0.8	3.2
3	7	FL (2) 6 S	1.0	1.0	1.0	3.0
3	9	Q (2) 6 S	0.3	0.7	0.3	4.7
A	9	FL (2) 7 S	1.0	1.0	1.0	4.0
7	B	FL (2) 8 S	0.4	0.6	2.0	5.0
8	A	FL (2) 8 S	0.4	1.0	0.4	6.2
4	7	FL (2) 8 S	0.5	1.0	0.5	6.0
8	8	FL (2) 8 S	0.8	1.2	2.4	3.6
5	7	FL (2) 8 S	1.0	1.0	1.0	5.0
4	C	OC (2) 8 S	3.0	2.0	1.0	2.0
5	C	OC (2) 8 S	5.0	1.0	1.0	1.0
F	B	VQ (2) 8 S	0.2	1.0	0.2	6.6
9	A	FL (2) 10 S	0.4	1.6	0.4	7.6
9	8	FL (2) 10 S	0.5	0.5	1.5	7.5
6	7	FL (2) 10 S	0.5	1.0	0.5	8.0
7	7	FL (2) 10 S	0.5	1.5	0.5	7.5
6	9	FL (2) 10 S	0.5	2.0	0.5	7.0
8	7	FL (2) 10 S	0.8	1.2	0.8	7.2
B	9	FL (2) 10 S	1.0	1.0	1.0	7.0
9	7	FL (2) 10 S	1.0	1.5	1.0	6.5
4	9	Q (2) 10 S	0.6	0.4	0.6	8.4
B	A	FL (2) 12 S	0.4	1.0	0.4	10.2
C	9	FL (2) 12 S	0.5	1.0	0.5	10.0
D	9	FL (2) 12 S	1.5	2.0	1.5	7.0
A	8	FL (2) 15 S	0.5	1.5	2.0	11.0
A	7	FL (2) 15 S	1.0	2.0	1.0	11.0
8	B	Q (2) 15 S	0.2	0.8	0.2	13.8
C	A	FL (2) 20 S	1.0	3.0	1.0	15.0
D	A	FL (2) 25 S	1.0	1.0	1.0	22.0



SWITCH	FLASH CODE	ON	OFF	ON	OFF	ON	OFF
A	B						
7	9	Q (3) 5 S	0.5	0.5	0.5	0.5	2.5
5	9	VQ (3) 5 S	0.2	0.3	0.2	0.3	3.8
0	C	VQ (3) 5 S	0.3	0.2	0.3	0.2	3.7
E	9	VQ (3) 5 S	0.3	0.3	0.3	0.3	3.5
3	C	FL (3) 6 S	0.5	1.0	0.5	1.0	2.5
2	B	FL (2+1) 6 S	0.3	0.4	0.3	1.2	3.5
A	B	Q (3) 6 S	0.3	0.7	0.3	0.7	3.7
F	A	FL (3) 8 S	0.5	1.0	0.5	1.0	4.5
0	B	FL (3) 9 S	0.3	1.0	0.3	1.0	6.1
B	7	FL (3) 9 S	0.8	1.2	0.8	1.2	4.2
B	8	FL (3) 10 S	0.3	0.7	0.3	0.7	7.1
C	8	FL (3) 10 S	0.4	0.6	0.4	0.6	6.8
C	B	FL (3) 10 S	0.5	0.5	0.5	0.5	7.5
C	7	FL (3) 10 S	0.5	1.5	0.5	1.5	5.5
D	B	FL (3) 10 S	0.6	0.6	0.6	0.6	7.0
D	7	FL (3) 10 S	1.0	1.0	1.0	1.0	5.0
3	8	FL (2+1) 10 S	0.5	0.7	0.5	2.1	5.7
8	9	OC (3) 10 S	5.0	1.0	1.0	1.0	1.0
B	B	Q (3) 10 S	0.3	0.7	0.3	0.7	7.7
D	8	FL (2 + 1) 10 S	0.5	0.5	0.5	0.5	1.5
1	B	FL (3) 12 S	0.5	1.5	0.5	1.5	7.5
E	A	FL (3) 12 S	0.5	2.0	0.5	2.0	6.5
E	7	FL (3) 12 S	0.8	1.2	0.8	1.2	7.2
B	6	FL (3) 12 S	1.0	1.0	1.0	3.0	5.0
4	8	FL (2+1) 12 S	0.8	1.2	0.8	2.4	6.0
5	8	FL (2+1) 12 S	1.0	1.0	1.0	4.0	4.0
1	8	FL (2+1) 13.5 S	1.0	1.0	1.0	4.0	5.5
F	7	FL (3) 15 S	0.3	1.7	0.3	1.7	10.7
9	D	FL (3) 15 S	0.4	1.0	0.4	1.0	11.8
0	8	FL (3) 15 S	0.5	1.5	0.5	1.5	10.5
F	8	FL (2+1) 15 S	0.6	0.3	0.6	0.3	1.4
0	9	FL (2+1) 15 S	0.7	0.5	0.7	0.5	1.9
1	9	FL (2+1) 15 S	0.7	0.7	0.7	0.7	2.1
6	8	FL (2+1) 15 S	1.0	2.0	1.0	5.0	5.0
1	C	VQ (3) 15 S	0.1	0.5	0.1	0.5	13.7
4	B	FL (3) 20 S	0.5	3.0	0.5	3.0	12.5
3	B	FL (3) 20 S	0.5	1.5	0.5	1.5	15.5
5	B	FL (3) 20 S	0.8	1.2	0.8	1.2	15.2
6	B	FL (3) 20 S	1.0	1.0	1.0	1.0	15.0



SWITCH	FLASH CODE	ON	OFF	ON	OFF	ON	OFF	ON	OFF	ON	OFF
A	B										
B	F	VQ (4) 4 S	0.25	0.25	0.25	0.25	0.25	0.25	0.25	0.25	2.25
B	D	Q (4) 6 S	0.3	0.7	0.3	0.7	0.3	0.7	0.3	0.7	2.7
8	D	Q (4) 6 S	0.4	0.6	0.4	0.6	0.4	0.6	0.4	0.6	2.6
1	D	FL (4) 10 S	0.5	1.0	0.5	1.0	0.5	1.0	0.5	1.0	5.0
2	D	FL (4) 10 S	0.8	1.2	0.8	1.2	0.8	1.2	0.8	1.2	3.2
F	E	Q (4) 10 S	0.3	0.7	0.3	0.7	0.3	0.7	0.3	0.7	6.7
B	E	FL (4) 12 S	0.3	1.7	0.3	1.7	0.3	1.7	0.3	1.7	5.7
4	F	FL (4) 12 S	0.5	0.5	0.5	0.5	0.5	0.5	0.5	0.5	8.5
C	E	FL (4) 12 S	0.5	1.5	0.5	1.5	0.5	1.5	0.5	1.5	5.5
3	D	FL (4) 12 S	0.8	1.2	0.8	1.2	0.8	1.2	0.8	1.2	5.2
A	D	Q (4) 12 S	0.3	0.7	0.3	0.7	0.3	0.7	0.3	0.7	8.7
4	D	FL (4) 15 S	0.5	1.5	0.5	1.5	0.5	1.5	0.5	1.5	8.5
8	E	FL (4) 15 S	1.0	1.0	1.0	1.0	1.0	1.0	1.0	1.0	8.0
7	D	FL (4) 15 S	1.5	0.5	0.5	0.5	0.5	0.5	0.5	0.5	10.5
D	E	FL (4) 16 S	0.5	1.5	0.5	1.5	0.5	1.5	0.5	1.5	9.5
C	D	FL (4) 20 S	0.3	3.0	0.3	3.0	0.3	3.0	0.3	3.0	9.8
5	D	FL (4) 20 S	0.5	1.5	0.5	1.5	0.5	1.5	0.5	1.5	13.5
0	D	FL (4) 20 S	0.5	1.5	0.5	1.5	0.5	4.5	0.5	0.5	10.5
3	F	FL (4) 20 S	1.5	1.5	1.5	1.5	1.5	1.5	1.5	1.5	9.5
0	F	Q (4) 20 S	0.5	0.5	0.5	0.5	0.5	0.5	0.5	0.5	16.5
E	E	Q (4) 28 S	0.5	0.5	0.5	0.5	0.5	0.5	0.5	0.5	24.5
6	F	FL (4) 30 S	0.5	0.5	0.5	0.5	0.5	0.5	0.5	0.5	26.5

SWITCH	FLASH CODE	ON	OFF	ON	OFF	ON	OFF	ON	OFF	ON	OFF
A	B										
D	D	Q (5) 7 S	0.3	0.7	0.3	0.7	0.3	0.7	0.3	0.7	2.7
E	D	Q (5) 10 S	0.3	0.7	0.3	0.7	0.3	0.7	0.3	0.7	5.7
E	8	FL (5) 16.5 S	5.0	1.5	0.5	1.5	0.5	1.5	0.5	1.5	3.5
5	F	FL (5) 20 S	0.5	0.5	0.5	0.5	0.5	0.5	0.5	0.5	15.5
9	F	FL (5) 20 S	0.8	1.2	0.8	1.2	0.8	1.2	0.8	1.2	11.2
9	E	FL (5) 20 S	1.0	1.0	1.0	1.0	1.0	1.0	1.0	1.0	11.0

SWITCH	FLASH CODE	ON	OFF	ON	OFF	ON	OFF	ON	OFF	ON	OFF	ON	OFF
A	B												
F	D	Q (6) 10 S	0.3	0.7	0.3	0.7	0.3	0.7	0.3	0.7	0.3	0.7	4.7
A	F	FL (6) 15 S	0.3	0.7	0.3	0.7	0.3	0.7	0.3	0.7	0.3	0.7	9.7
7	F	FL (6) 15 S	0.5	1.0	0.5	1.0	0.5	1.0	0.5	1.0	0.5	1.0	7.0
A	E	FL (6) + LFL 15 S	0.5	1.0	0.5	1.0	0.5	1.0	0.5	1.0	0.5	1.0	7.0

SWITCH	FLASH CODE	ON	OFF	ON	OFF	ON	OFF	ON	OFF	ON	OFF	ON	OFF	ON	OFF
A	B														
6	E	VQ (6) + LFL 10 S	0.2	0.3	0.2	0.3	0.2	0.3	0.2	0.3	0.2	0.3	0.2	0.3	2.0
7	E	VQ (6) + LFL 10 S	0.3	0.3	0.3	0.3	0.3	0.3	0.3	0.3	0.3	0.3	0.3	0.3	4.4
2	F	Q (6) + LFL 15 S	0.2	0.8	0.2	0.8	0.2	0.8	0.2	0.8	0.2	0.8	0.2	0.8	7.0
2	E	Q (6) + LFL 15 S	0.3	0.7	0.3	0.7	0.3	0.7	0.3	0.7	0.3	0.7	0.3	0.7	7.0
3	E	Q (6) + LFL 15 S	0.6	0.6	0.6	0.6	0.6	0.6	0.6	0.6	0.6	0.6	0.6	0.6	5.8
8	F	VQ (6) + LFL 15 S	0.3	0.3	0.3	0.3	0.3	0.3	0.3	0.3	0.3	0.3	0.3	0.3	9.4

SWITCH	FLASH CODE	ON	OFF	ON	OFF	ON	OFF	ON	OFF	ON	OFF	ON	OFF	ON	OFF	ON	OFF	ON	OFF
A	B																		
4	E	VQ (9) 10 S	0.2	0.3	0.2	0.3	0.2	0.3	0.2	0.3	0.2	0.3	0.2	0.3	0.2	0.3	0.2	0.3	0.2
5	E	VQ (9) 10 S	0.3	0.3	0.3	0.3	0.3	0.3	0.3	0.3	0.3	0.3	0.3	0.3	0.3	0.3	0.3	0.3	0.3
1	F	Q (9) 15 S	0.2	0.8	0.2	0.8	0.2	0.8	0.2	0.8	0.2	0.8	0.2	0.8	0.2	0.8	0.2	0.8	0.2
0	E	Q (9) 15 S	0.3	0.7	0.3	0.7	0.3	0.7	0.3	0.7	0.3	0.7	0.3	0.7	0.3	0.7	0.3	0.7	0.3
1	E	Q (9) 15 S	0.6	0.6	0.6	0.6	0.6	0.6	0.6	0.6	0.6	0.6	0.6	0.6	0.6	0.6	0.6	0.6	0.6



SWITCH	FLASH CODE	ON	OFF	ON	OFF	ON	OFF	ON	OFF
A	B								
MORSE CODE () INDICATES LETTER									
7	8	MO (A) 6 S	0.3	0.6	1.0	4.1			
7	B	MO (A) 8 S	0.4	0.6	2.0	5.0			
8	8	MO (A) 8 S	0.8	1.2	2.4	3.6			
B	8	MO (U) 10 S	0.3	0.7	0.3	0.7	0.9	7.1	
C	8	MO (U) 10 S	0.4	0.6	0.4	0.6	1.2	6.8	
D	8	MO (U) 10 S	0.5	0.5	0.5	0.5	1.5	6.5	
9	8	MO (A) 10 S	0.5	0.5	1.5	7.5			
8	9	MO (D) 10 S	5.0	1.0	1.0	1.0	1.0	1.0	
A	8	MO (A) 15 S	0.5	1.5	2.0	11.0			
F	8	MO (U) 15 S	0.6	0.3	0.6	0.3	1.4	11.8	
0	9	MO (U) 15 S	0.7	0.5	0.7	0.5	1.9	10.7	
1	9	MO (U) 15 S	0.7	0.7	0.7	0.7	2.1	10.1	
7	D	MO (B) 15 S	1.5	0.5	0.5	0.5	0.5	0.5	0.5 10.5

Trouble Shooting

Problem

Remedy

Lantern will not activate.	<ul style="list-style-type: none"> • Ensure internal toggle switch is set to the 'ON' position. • Ensure lantern is in darkness. • Wait at least 60 seconds for the program to initialise in darkness. • Ensure switch setting is on a valid code (not unused flash code). • Ensure battery terminals are properly connected. • Ensure battery voltage is above 12volts.
Timing codes will not change.	<ul style="list-style-type: none"> • Turn rotary switches several times to ensure contacts are clear.
Lantern will not operate for the entire night.	<ul style="list-style-type: none"> • Reducing the light output intensity or duty cycle (flash code) will reduce current draw on the battery.



Sealite Lantern Warranty

Activating the warranty

Upon purchase, the Sealite warranty must be activated for recognition of future claims. To do this you have two (2) options:

1. Postal registration
 - Please complete the Sealite Warranty Registration card and return to Sealite within 30 days of your purchase.
2. Online registration
 - Please complete the Online Registration form at;

www.sealite.com.au or www.sealiteusa.com

Sealite Pty. Ltd. will repair or replace your lantern in the event of electronic failure for a period of three years from the date of purchase.

The unit must be returned to Sealite Pty. Ltd. freight prepaid.

Warranty Conditions

1. The warranty is applicable to lanterns manufactured from 1/1/2000.
2. The lantern must be installed in accordance with Sealite instructions.
3. No modifications to the original specifications determined by Sealite shall be made without written approval of Sealite Pty. Ltd.
4. Input voltage shall not exceed those recommended for the product.
5. Warranty does not cover damage caused by the incorrect replacement of battery in the SL15, SL60 or SL70 lantern models.
6. Replacement of battery is excluded from the warranty.
7. No recognition shall be given to flooding, or damage incurred from misuse of lanterns.
8. Solar modules are covered by individual manufacturers' warranty.

Information in this manual is subject to change without notice and does not represent a commitment on the part of the vendor. Sealite products are subject to certain Australian and world-wide patent applications.



Head Office

Sealite Pty Ltd
11 Industrial Drive
Somerville, Vic 3912
Australia
Tel: +61 3 5977 6128
Fax: +61 3 5977 6124
Email: info@sealite.com.au
Internet: www.sealite.com.au

USA Customers

Sealite USA
29 Gilford East Drive
Gilford, NH 03249
USA
Tel: (603) 524-6066
Fax: (603) 524-8100
Email: info@sealiteusa.com
Internet: www.sealiteusa.com