

# SL15

## 1-2nm+ Solar Marine Lantern

*This equipment complies with requirements of the U.S. Coast Guard in 33 CFR part 66*

**Next  
Generation**

Single LED Optic ...  
Brighter, more efficient

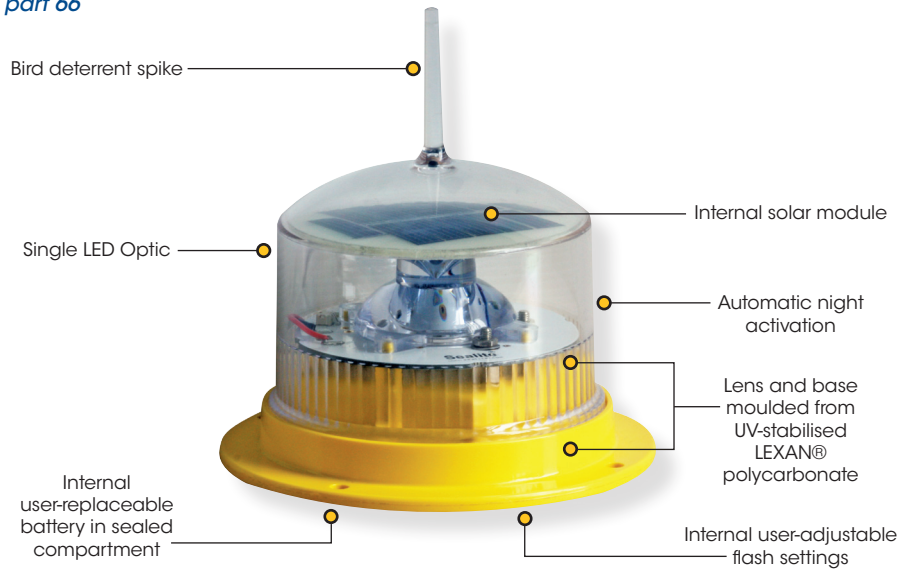

### The Sealite Advantage

- User-adjustable flash characters
- User-replaceable battery in sealed battery compartment
- NiMH battery for long service life & wide temperature range
- Completely sealed & self-contained using advanced UV-sealing
- Installs in minutes & operates maintenance-free for up to five years
- IP68 waterproof

**The Sealite SL15 1-2nm+ compact LED light is exceptional value and incorporates some of the most advanced technology available. In the tradition of Sealite lanterns, the SL15 is designed to be maintenance-free and have a service life of over 5 years.**

The SL15 can be installed in minutes and requires no operator intervention. The SL15 has a rotary switch to allow users to change the flash character of the light without the need for special tools or programmers.

During daylight hours the solar module will charge the battery, and the lantern will automatically begin operation at dusk – once the ambient light threshold drops sufficiently.

The SL15 features Sealite's Single LED Optic which boasts exceptional power to light output efficiency. The tough outer polycarbonate lens incorporates an environment-friendly spike – deterring unwelcome bird life.

The internally housed battery is user-replaceable after years of reliable service.

The unit is sealed using advanced UV-sealing, enabling a rugged and completely waterproof seal capable of prolonged and deep immersion (IP68).

#### Optional ON/OFF Switch

The SL15 is also available with an optional ON/OFF switch for temporary installations such as worksites.



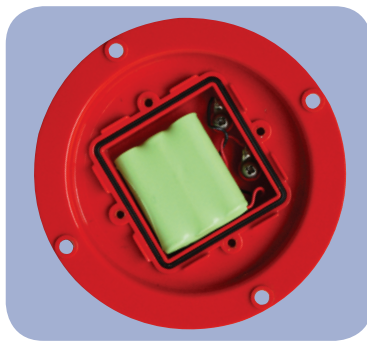

User-replaceable battery

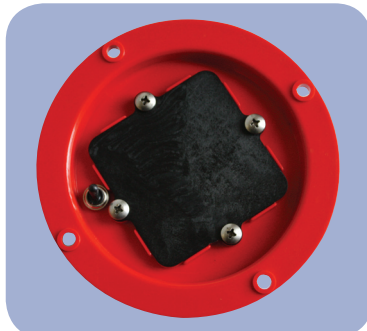

SL15 with optional ON/OFF switch

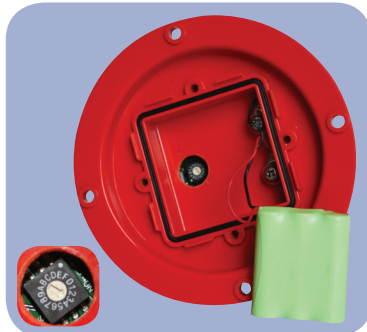

Flash characteristic is selected via internal rotary switch located in the battery compartment

### User-Adjustable IALA Flash Characteristics

FLASH SETTING CODE	Flash Sequence (on, off, on...)
0	STEADY LIGHT (intensity reduced)
1	0.5, 1.0
2	0.5, 3.5
3	1.0, 3.0
4	0.5, 5.5
5	0.3, 0.7
6	0.3, 0.7, 0.3, 0.7, 0.3, 0.7, 0.3, 15.7
7	0.3, 1.7
8	0.3, 2.2
9	0.5, 2.0
A	0.3, 2.7
B	0.5, 2.5
C	0.7, 2.3
D	0.5, 4.5
E	1.0, 4.0
F	Custom Setting

Other flash patterns are available on request

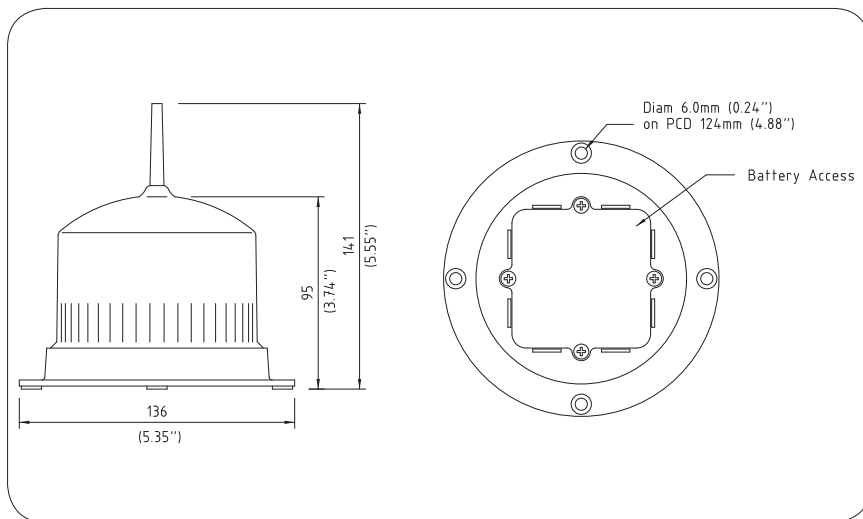

## SPECIFICATIONS •

### Light Characteristics

Light Source

Available Colours

Maximum Available Intensity (cd)†

Visible Range (nm)

Horizontal Output (degrees)

Vertical Divergence (degrees)

Reflector Type

Available Flash Characteristics

Intensity Adjustments

LED Life Expectancy (hours)

### Electrical Characteristics

Current Draw (mA)

Circuit Protection

Nominal Voltage (V)

Autonomy (days)

Temperature Range

### Solar Characteristics

Solar Module Type

Output (watts)

Solar Module Efficiency (%)

Charging Regulation

### Power Supply

Battery Type

Battery Capacity (Ah)

Nominal Voltage (V)

Battery Service Life

### Physical Characteristics

Body Material

Lens Material

Lens Diameter (mm/inches)

Lens Design

Mounting

Height (mm/inches)

Width (mm/inches)

Mass (kg/lbs)

Product Life Expectancy

### Certifications

CE

Quality Assurance

Waterproof

### Intellectual Property

Patents

Trademarks

### Warranty \*

### Options Available

1 LED

Red, Green, White, Yellow, Blue

Red - 6.2 Green - 7.6 White - 6.8 Yellow - 5.9

1-2+

360

7

Single LED Optic

16 user-adjustable IALA flash characteristics (other flash patterns available on request)

32 automatic step-down settings based on power demand of flash code selection, from 100% at 10% duty cycle through 25% at fixed on >100,000

Refer to Sealite Power Calculator

Integrated

3.6

>50 (14 hour darkness, 12.5% duty cycle)

-40 to 80°C

Multicrystalline

0.45

14

Microprocessor controlled

High grade NiMH - Environmentally friendly

1.6

3.6

Average 5 years

LEXAN® Polycarbonate - UV-stabilised

LEXAN® Polycarbonate - UV-stabilised

98 / 37/8

Single LED Optic

4 x 6mm mounting holes

141 / 5 1/2

136 / 5 3/8

0.5 / 1 1/8

Up to 12 years

EN61000-6-3:1997. EN61000-6-1:1997

ISO9001:2008

IP68

US Pat. No. 6,667,582. AU Pat. No. 778,918

SEALITE® is a registered trademark of Sealite Pty Ltd

3 years

- ON/OFF switch
- Custom flash patterns
- 50mm pole mount adapter plate



• Specifications subject to change or variation without notice

\* Subject to standard terms and conditions

† Intensity setting subject to solar availability